

SPY CRAFT

THEME PROGRAMME RESOURCES



'Spycraft' is a theme based programme resource primarily aimed at the Beaver and Cub Scout Sections.

Presented are a number of projects and ideas that can form the core of your programme over a number of meetings. The 'Mission' is an afternoon or day long outdoor activity.

'Spycraft' is a play based programme taking James Bond and the whole spy based genre of films, tv shows and cartoons. It is centered around 'secret stuff' - knowledge of survival, disguise, sneaking, miniature tools and gadgets, problem solving, fitness and dexterity and, of course, missions.

The ideas presented in this resource are only a snapshot of the many possible activities that can be undertaken. The members of your Sections will be full of possibilities. The internet hosts a vast collection of ideas in this area that can be used for 'spy based' school activities and parties.

This resource presents tried and tested ideas that many Sections have used before and we know work with a bit of preparation. Storylining and 'presenting of context' is vital in any theme based programme. The Scouts need to know what is going on and to 'buy into' the adventure and play aspect of this theme. The Mission or missions enable Section teams (Lodges, Sixes, Patrols) to work together, think out problems and solutions and work collectively to overcome the various challenges.

To run a successful 'Mission' activity you will need extra help and it will be an opportunity to contact the older Scouts and Patrol Leaders and the Venture and Rover Sections to lend a hand and create and man bases during the activity.

Like all of our programme it follows the plan, do, review model. At an early stage of idea generation some of the pages of this resource can be shared to get the idea of the theme rolling, more ideas will be forthcoming and before long the plan will be cast. The 'doing' will be fun and enjoyable and finally the review can capture the learning, knowledge and advancement of your Scouts before moving on to your next programme adventure.

Pages in this resource are designed to be printed out and used by Section teams, others relate to the background preparation aspects to assist Scouters preparing the adventure.

SPY CRAFT



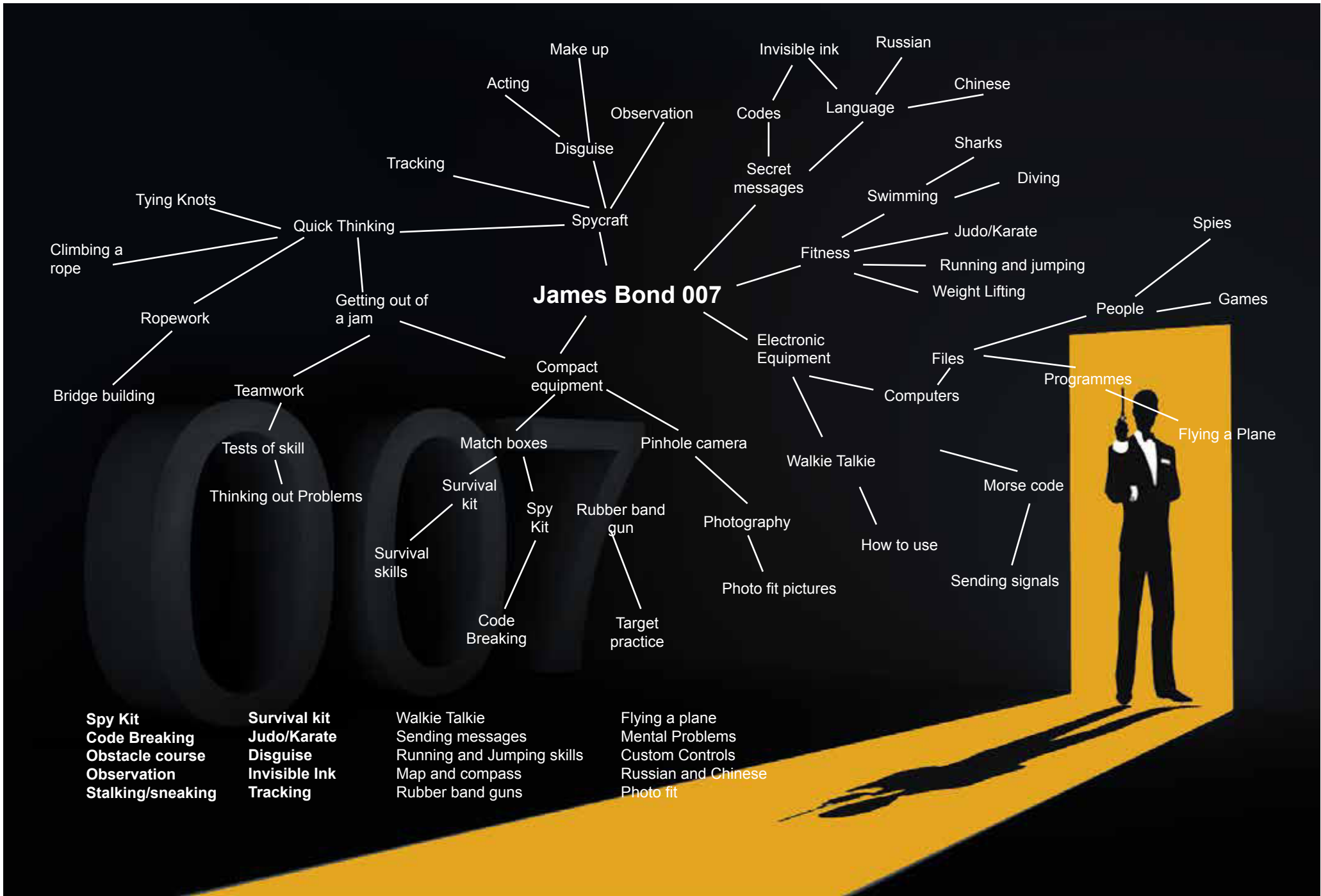

Spy Kit
Code Breaking
Obstacle course
Observation
Stalking/sneaking

Survival kit
Judo/Karate
Disguise
Invisible Ink
Tracking

Walkie Talkie
 Sending messages
 Running and Jumping skills
 Map and compass
 Rubber band guns

Flying a plane
 Mental Problems
 Custom Controls
 Russian and Chinese
 Photo fit

SNEAKING

Sneaking around without been seen is a skill that is best learned by practice.

The key to sneaking is to hide behind natural cover such as walls and trees. When ever cover is available peep out from the side.

Avoid standing out in the open or on the skyline where you can be seen.

Move slowly and with care, don't stand on twigs or stones that might make noise.

Use cloths with muted colours that do not stand out - in nature use camouflage.

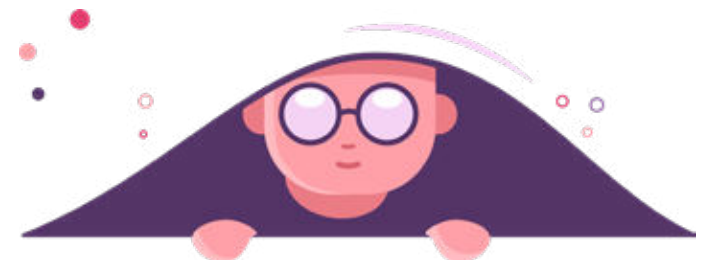

Practice games

Sleeping Pirate

The "pirate" sits on a chair blindfolded with a bunch of keys under the chair. Scouts crawl and move towards the 'pirate' as silently as possible to try and get the keys undetected and return to start line. The 'pirate' can point in the direction of any sound he might hear. If he points at the Scout - the Scout is out.

Get to the flag

The flag is placed within a protected area - small clearing in a wood. Scouts in teams have to sneak up to the clearing and capture the flag. The area is protected by 'guards' who move backwards and forwards around the area. If spotted a Scout is out.

Kick the can

Traditional hide and seek game. Scouts go and hide and the catcher tries to find them while also protecting the 'tin can'. Scouts hide

and then sneak towards the can. If they are caught they become part of the catcher team. If not the Scout tries to 'kick the can' and restart the game.

Follow people undetected and report on their movements

Scouts in teams are assigned a person to follow - venture scout - around the town for a period of time and take notes of their movements, contacts and actions. They must do so undetected. The assigned person will also take notes of each time he sees the 'followers'.

Points are awarded for correct and accurate reporting on their return. Points deducted for every time a team member is observed.



CAMOUFLAGE

Sneaking in nature can be harder to do than sneaking in an urban area. In open areas the shape of a person is easy to spot. Humans and animals have keen survival skills and can spot patterns and differences in the landscape and their surroundings. If you are trying to observe animals then it is important to get as near as possible without being detected.

The trick is to blend in, to break up shapes and to keep your body as low as possible. Moving slowly and silently.

Simple tricks will help. If you wear a hat you can place tufts of grass around it. Dirtying your face and skin will also help to cover up bright areas. Hold a small branch in your hand to hide behind as you move forward.

Colours should be muted - browns and greens - colours that will blend in to the surroundings easily.



Practice Skills

Get ready

Scouts are invited to get camouflaged - dirty up skin, place grass and twigs around their bodies to disguise their shape.

Hiding in plain sights

Scouts are given a short period of time to hide in a field with tall grass. Scouters turn around and observe the field and see if they can spot the Scouts.

Wildlife photo

Scouts are challenged to use their sneaking and camouflage skills to take a picture of a wild animal or bird as closeup as possible.

Hello I here

A play area is defined with various cover (tall grass, bushes, rocks, trees). A Scouter sits in a position where he can see the whole area from all sides. Scouts starting from various points try to sneak up to the Scouter undetected and place their hand on his/her shoulder.

The Scouter should move around and also stand still observing in different directions to give the Scouts some opportunity to move undetected and arrive at the location of the Scouter.



TRACKING



Turn right



Follow this trail



Turn left



Message hidden four paces from here



Follow this trail



Follow this trail



Message hidden 12 paces from here



Gone home

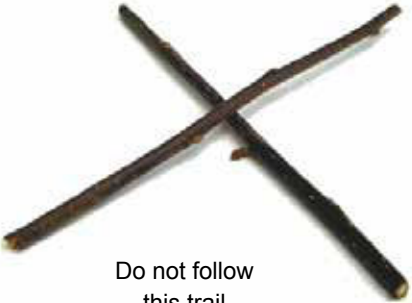

Do not follow this trail



Group has split up four have taken this trail and two the other one

Q'S LAB

Q's Lab is the place where specialist equipment is created to help on spying missions.

- A spy kit
- A 'gun'
- A periscope
- Code information
- Making a compass
- A pen survival kit

Spy Kit

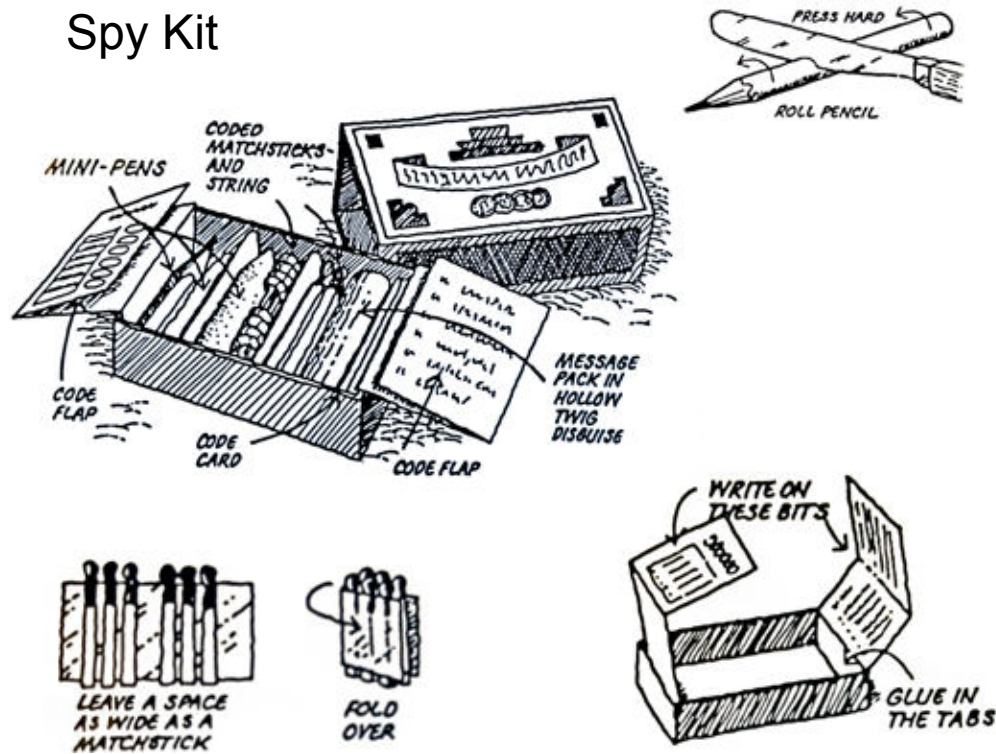

Find north using a watch

Point the hour hand at the sun and divide the angle between the hour hand and 12 o'clock. this line is pointing south. once you know the south point you can figure out the other points of the compass.

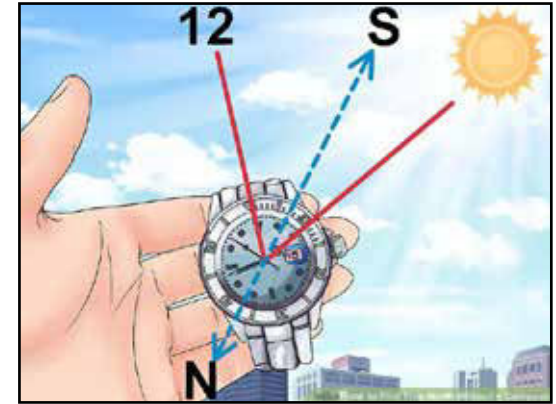

A metal item such as a paper clip or a small needle becomes a compass needle when it is magnetized and can be suspended to allow free movement that is not affected by wind or other forces.

To magnetize the needle use a magnet and stroke the needle about 20 - 30 times in the same direction.

Find a small pool of water away from the wind and careful place your needle either on a small piece of grass or leaf. The surface tension of the water will prevent the needle from sinking and it will turn easily clockwise or counter-clockwise to orient itself north-south on the grass or leaf.

Frame Code

The frame code uses a grid system to determine the position of letters. The message is then written graphically as shown. The dot indicates the second letter in the frame.

AB	CD	EF
GH	IJ	KL
MN	OP	QR

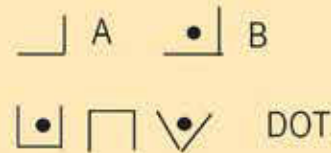

Code Wheel

A Code wheel is used to create secret messages by replacing one letter for another.

The first letter in the message is the letter that matches with A on the outer circle so it can be encoded

MEET AT THE CLOCK

PHFFJ PJ JAF NTVNC

The Romans invented the stick code. This was created by winding a leather strip around a stick of a special thickness. The message was then written on the leather and when unraveled would appear to be random letters

It could only be decoded if you has a similar sized stick.



Secret Codes



Code Sheet

Number Code Morse code

A	1	Alpha	..-
B	2	Bravo	---..
C	3	Charlie	---..-
D	4	Delta	---..
E	5	Echo
F	6	Foxtrot	..-..-
G	7	Golf	---..-
H	8	Hotel-
I	9	India	..--
J	10	Juliet	..-...-
K	11	Kilo	---..-
L	12	Lima	..-..-
M	13	Mike	---..
N	14	November	---..
O	15	Oscar	---..-
P	16	Papa	..-...-
Q	17	Quebec	---...-
R	18	Romeo	..-..-
S	19	Sierra	...--
T	20	Tango	---..
U	21	Uniform	..-..
V	22	Victor	...--
W	23	Whiskey	---...-
X	24	X-Ray	---...-
Y	25	Yankee	---...-
Z	26	Zulu	---...-

TAP CODE

	1	2	3	4	5
1	A	B	C/K	D	E
2	F	G	H	I	J
3	L	M	N	O	P
4	Q	R	S	T	U
5	V	W	X	Y	Z

S=43 A=11 Y=54

PIGPEN

A	B	C	J	K	L
D	E	F	M	N	O
G	H	I	P	Q	R

S	W
T	X
U	Y
V	Z

S=V A=J Y=<

Number code

Each letter is assigned a number. So a message will look like this:-

Meet in the park - 13,5,5,20 9,14 20,8,5 16 1,16,11

Morse code

Morse code is useful for sending signals by light. You could use a torch or in daylight a mirror to reflect the sunlight. Morse code is presented as a series of dots and dashes. A dot is a quick flash and a dash is a longer flash.

So a message will look like this:-

Come here now -



Tap Code

Tap code is very useful for tapping out a message on a table to signal a message to another person. The grid provides the combination of taps for each letter. So, to tap out the letter O you need to tap 3 times, then a short gap and then tap 4 times.

So a message might look like this:-

Keep quite -

1/3, 1/5. 1/5, 3/5 4/1,4/5.2/4,4/4,1/5

Pigpen

The penpig code is a symbol based code. Letters are placed within a grid and the shape of the grid indicates the letter.

So a message will look like this:-

Go to the hut

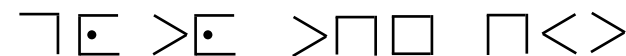

Print off a reference copy for each section team

PERISCOPE

A periscope is a useful piece of 'spy kit' as it enables you to look over walls and around corners. You can make a periscope with some basic materials.

Firstly, you need two small mirrors, a square cardboard box tube, a cutting knife and some double sided tape.



Two small mirrors for viewing



Make a cardboard tub or use milk cartons -you will need two of them. Cut off the tops of a cartons and tape them together to make a long cardboard tube.

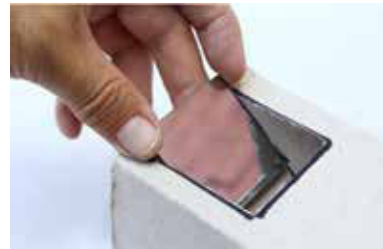

Place mirror on the side of the tub and mark around it



Cut three sides of the square to create a flap for the mirror.



Place some double sided tape on the back of the mirrors and fix them to the flaps.



The mirrors should be positioned at 45 degrees to each other and your periscope is now ready for action.

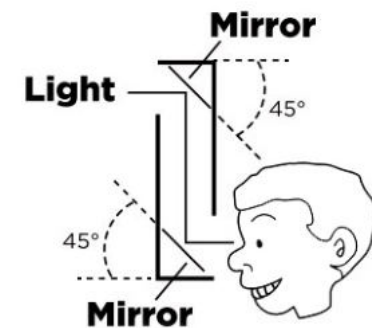
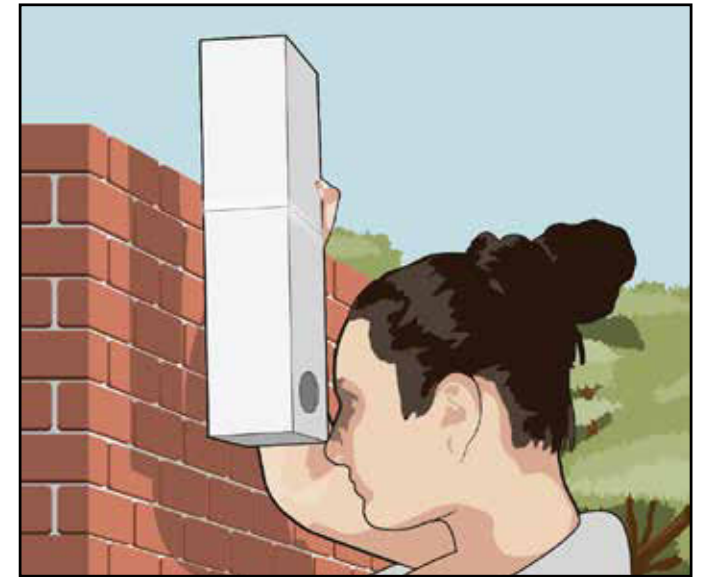

SENSES TRAINING (KIM'S GAMES)

Taste

Various foodstuffs are chosen with distinctive tastes and small pieces are placed on a tray/plate. The Scouts come individually – eyes blindfolded and taste small quantities of each item and guess what they are tasting.

Sight

Place 40 objects on a table and give Section teams 30 seconds to look at them. Cover the items and invite teams to list the objects.

32 playing cards are placed on a table in 8 rows of 4 cards. Teams are invited to view the cards for 30 seconds. The cards are covered and the teams must repeat the sequence with another deck of cards.

Spot the difference

Teams observe spot the difference pictures (find on the internet) within a time limit of one minute.

Touch

10 corn kernels, 10 grains of rice, 10 dried peas, and 10 dry beans are mixed. The player is blindfolded and must sort these items. Who can correctly sort the most within 60 seconds?

Teams stand one behind the other. The Scout at the back is given a list of letters. The Scout then draws each letter on the Scouts' back in front of him using his/her finger. Scouts then pass on the letter sequence in turn to each member of the team. No talking allowed. The Scout at the front then writes down the letters and they are compared to the original list.

A number of distinctly shaped objects are placed in a cloth bag. Scouts in section teams are invited to share and feel the bag to identify the objects by touch.

Teams stand in a line and are blindfolded. 10 objects are available for the game. Each object is placed in the hands of the first member of the team and passed along

the line to the last member. When all items have been shared the team take off their blindfolds and try to list the objects and the sequence that they were shared. Items might include - coin, sandpaper, paper clip, key thumbtack, lollipop stick, rubber band, bottle top, button, stone.

Smell

Create a smell trail using distinct smells (perfume, onion, orange peel, and lemon peel). Each smell is rubbed onto a piece of card and the cards are placed on trees in a forest. Each card has a letter on it. Section teams must follow a selected trail listing the letter from each card discovered.

Various foodstuffs are chosen (e.g. mustard, onion, vinegar, garlic etc.) - these are cut up if necessary, placed into beakers and covered with a cloth. The children come individually – eyes blindfolded and have to guess what is in the bowl. Whoever has the best nose, wins.

Sound

A recording is made of various common sounds -20 sounds. The recording is played back to the section and teams are invited to identify and list each sound.

A recording is made of everyone in the section saying a two word phrase. The recording is played back to teams in turn who must identify each person talking on the recording.

Memory

All players write down within a few seconds, the names of all the shop/businesses on the main street of town in the right order. Variation: Everyone writes the names of all the restaurants in town.

Sit in a circle and pass around a number of items. See who can list the objects in sequence from memory.



TEAM TRAINING

Mine field

A play area is setup. In this space are placed a collection of flat items to act as mines, balls, sticks, paper plates.

Section team members are blindfolded except the team leader. The team leader then guides his/her team through the mine field in the shortest time. If a scout touches a mine they must return to the start.



Electric Fence

An electric fence is setup using duct tape at an average height of just above waist height of those taking part. You must not be able to step over it.

The object of the game is, collectively, to get all the team members over the fence carefully and without injury - not diving or mad stuff. The game starts with all the team on one side of the fence and completed when all the team are on the others side of the fence.



Lazer beams

A 'lazer maze' is created in a corridor (actual corridor or a corridor created using chairs). The lazers can be created with duct tape or string. Teams are challenges to get their whole team through the maze in the quickest time. Touching a 'lazer beam' means the scout must return to the start.

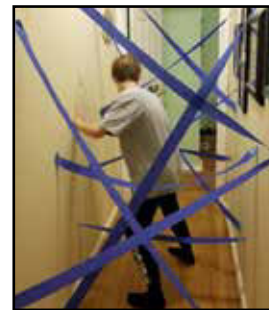

Team text

A play area is created in the middle of the play area is a table. there should be at least 1 meter distance from edge of the table to the edge of the play area - a participants should not be able to touch the table.

A sheet of paper is provided taped to a table top. A heavy marker is taped to six tape strings. The object of the challenge is for the team to write a code word on the paper from a distance outside of the play area using the pen and the tape strings.



[Discover more ideas here](#)

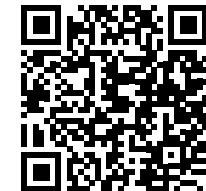

RUBBER BAND SHOOTERS

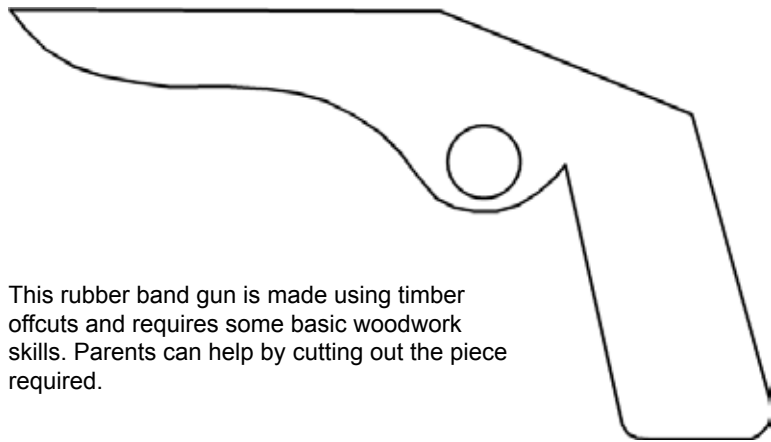

This rubber band gun is made using timber offcuts and requires some basic woodworking skills. Parents can help by cutting out the piece required.



Only play with these toys using a range of targets to shoot at.

This gun is made from some old cardboard boxes.

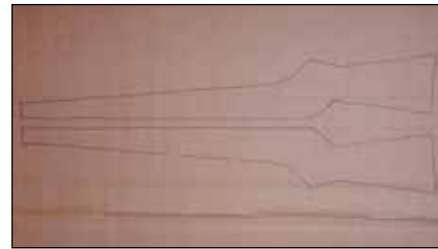

Start by marking out the shape on cardboard. you need to shape with a small gap the width of a clothes peg between them.

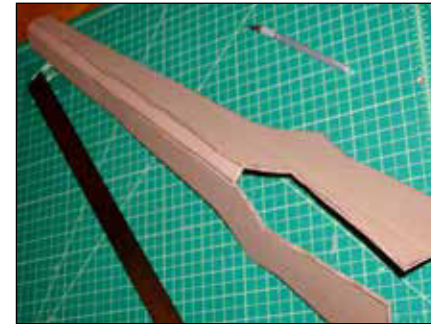

Fold up the shape and bind together with tape



Make sure frame is straight



Fix the clothes peg to the frame



Make some rubber band 'ammo' and you are good to go.



Other designs possible

INVISIBLE INK

Visible Ink messages are created using lemon juice which when dried disappears. It reappears again when the paper is heated up with a hairdryer or an iron.



Use cotton buds or paint brushes for writing your message



Reveal your message using a heat source such as a hot electrical bulb, a hair dryer or an iron.



WINDOW CARD CODES

A window card code device is comprised of two parts - a card with text hiding the hidden message and a card with windows.

The text card can be a series of words or letters which are placed in rows on the card.

To discover the code the receiver needs to have the window card that is placed over the text card to reveal the hidden message.

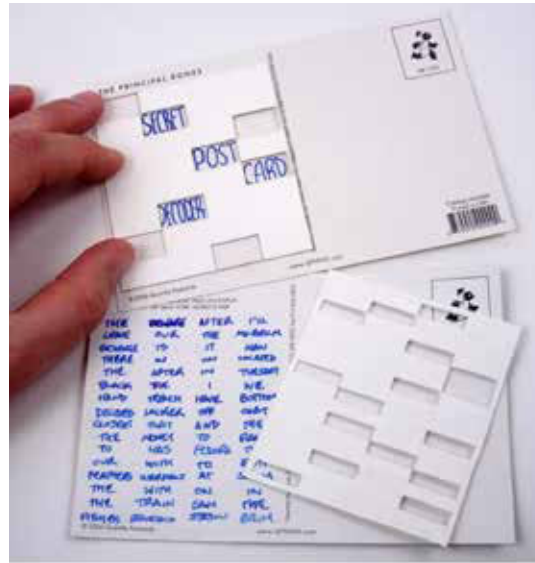
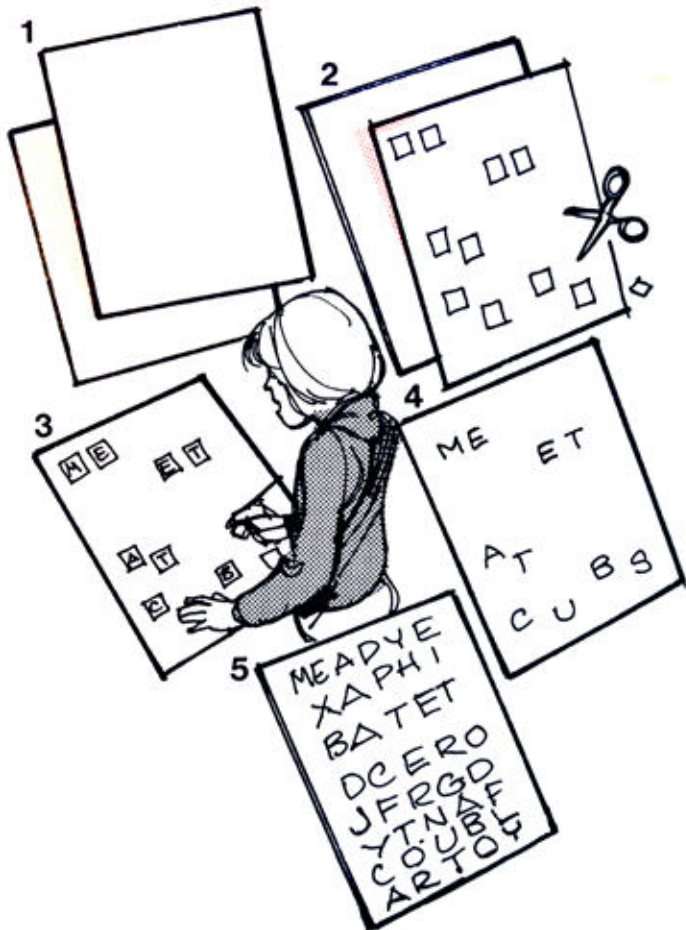

Card code in use - a postcard is sent with a series of words on it. The receiver places window card over text to reveal message.

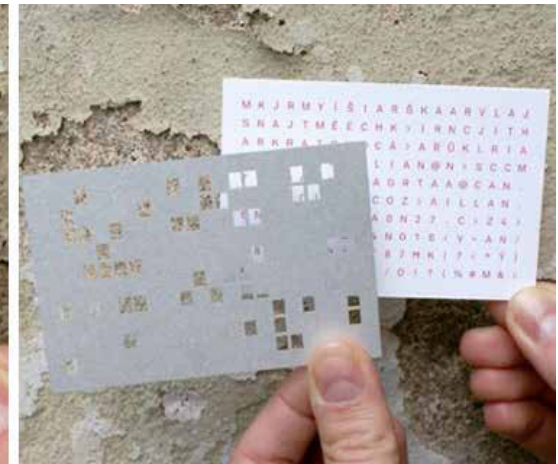

Recovered text card hidden in secret drop point. Then window card used to reveal hidden message.

SURVIVAL KIT



Everything in your kit needs to be small and useful

- Some ideas for items to include:-
 A few matches and striker paper (wrap in 'Cling film' to protect them.)
 A magnetised needle to make a compass
 Some safety pins
 A few fish hooks
 Paper clips
 A few birthday candles - fire lighting
 Band aids
 Cotton buds
 Small mirror - signaling (Broken piece of CD disk)
 Small straws packed with tinder for fire lighting
 A key fob light
 A safety craft knife blade (wrapped with tape)
 A small roll of duct tape
 Rubber bands
 Flint striker from old BIC lighter
 A compass
 Survival instructions
 Dental floss - very strong and used for tying things
 Fishing line
 A nut and bolt
 Small pencil
 Paracord - wrapped around the outside of the box.



Duct tape is cut into small strips and wrapped around stick.



Cut down drinking straws packed with cotton wool to use as fire tinder - seal with tape.

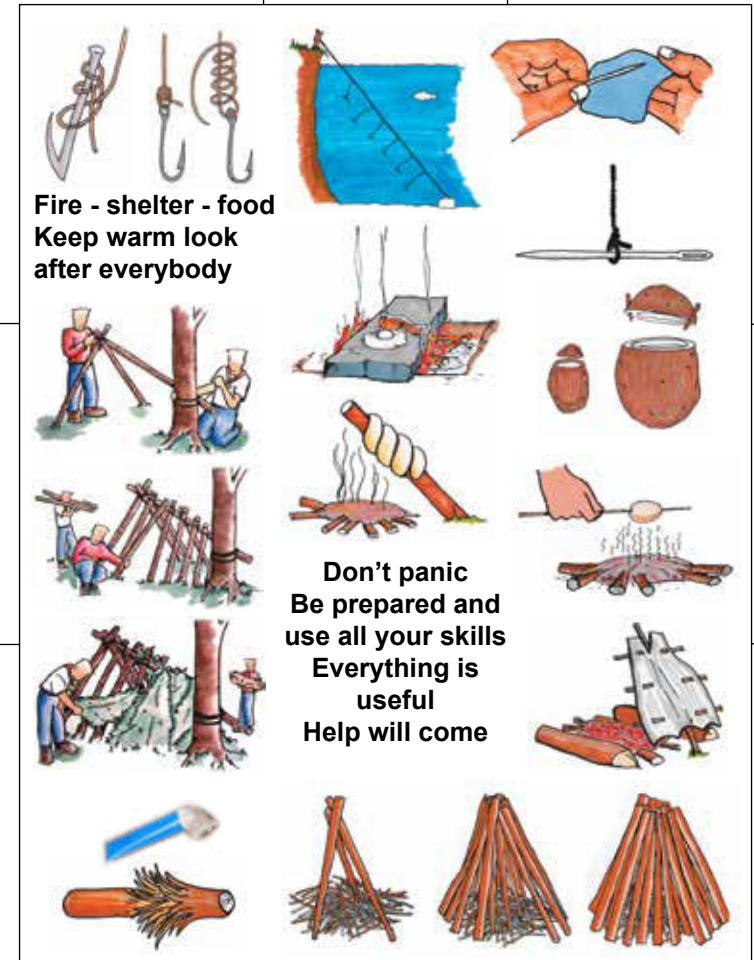

**Fire - shelter - food
 Keep warm look
 after everybody**

**Don't panic
 Be prepared and
 use all your skills
 Everything is
 useful
 Help will come**

Print and fold down to fit in your kit

[Tic tac survival kit demo](#)



THE MISSION

The Mission is the afternoon or day long activity adventure for the Section. It will be played in open countryside or the local park.

The Mission consists of a number of team based games which challenge the skills of the team. Once completed they receive a piece of a puzzle which together reveal the final location.

You will need some additional help (Patrol Leaders, Venture Scouts to assist at the bases.

The bases are arranged in a circular fashion so that each team starts at a different point. Once all the bases are complete they move to final location for the finish.

Ten bases are provided here as an idea pool and can be used as the location allows. You will need to check out the play area and determine the best location for each challenge.

All good wide games have a storyline.

In this case your section teams (lodges, sixes, patrols) are a team of agents who have recovered a dangerous substance from an terrorist science lab. In order to protect the substance they injected it into an egg, that keeps it stable for a period of time. The clock is now ticking and the egg must now be taken to their secret lab to be made safe. if the egg breaks then the team will face immediate death and the world will be infected by a deadly virus.

Their mission is to discover the secret base where their scientist can destroy the substance.

The bases

The game starts by an explanation of the mission, the rules of the game and the area in which the game is to be played.

Teams are given the mission envelope - in the envelope is a cutup map. A code reference sheet and some pencils. The team must recreate the map to show the location of the first clue.

The team are also given an egg and three lives in the form of three piece of wool that are tied around the team leaders arm.

Lives - the team are expected to protect the egg and bring it to the final location unbroken, however he team maybe unfortunate and break the egg in which case they will have to redeem a life for a replacement egg. A time penalty is imposed at the final task.



Challenge one

The team are presented with a recording of a tapping code that they must decipher to reveal next location.

1



Challenge two

The team are presented with a play area. In the play area are a collection of lightweight logs with wire stables nailed into their tops. The previous clue directs them to the correct log. On their side of the play area they are presented with six strings that are attached to a hook. Collectively they must attach the hook to the log and lift it to safety to reveal the next clue which is attached to the bottom of the log.

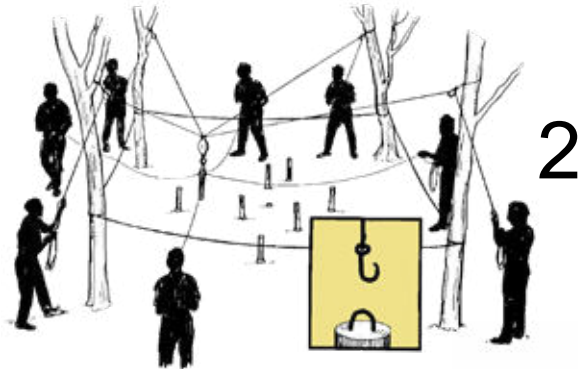

Challenge three

To arrive at the next location the team must follow a tracking trail consisting of natural trail markers and some chalk based markers if the area allows.

3



Challenge four

This challenge requires the team to sneak into an enclosed area and recover the next clue which is written on a blackboard. Guards patrol the area.



Challenge five

The team have to get over an electric fence. An electric fence is created between two trees or poles. The fence is set above waist height. On the other side of the fence the team have to complete a blind fold trail to find the clue.

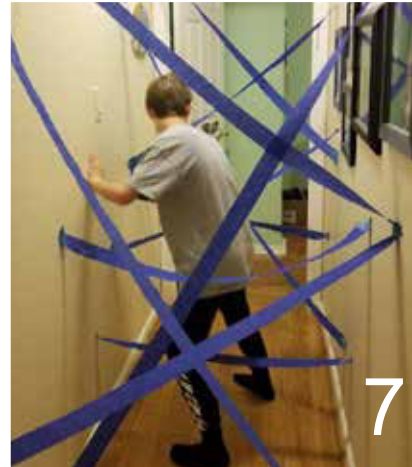
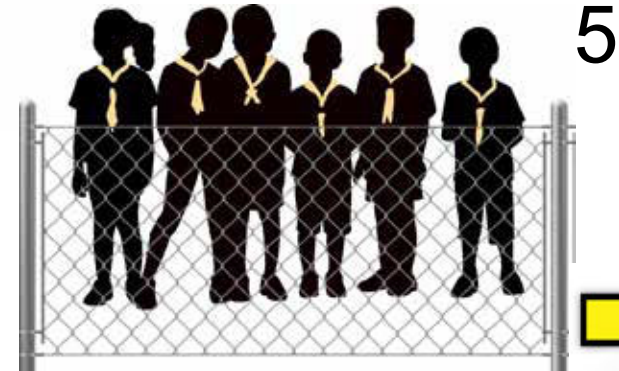

Challenge six

The team have to get across a swamp using a plank to get to clue location then break a code to find next location.

Challenge seven

The team have to get through a lazer maze to get to the safe containing the next clue. The code for the combination lock is provided on previous clue.

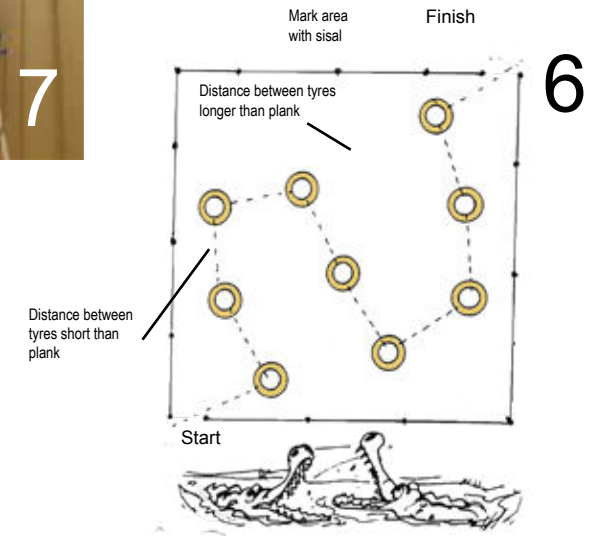

Challenge eight

The team are presented with a water pipe. At the end of the pipe is a small bottle with a clue inside it. The problem is to get the bottle out of the tube. Nearby is a bucket of water (that can't be moved from its locations and some cups. Teams have to transport water using cups to flow the bottle within reach.

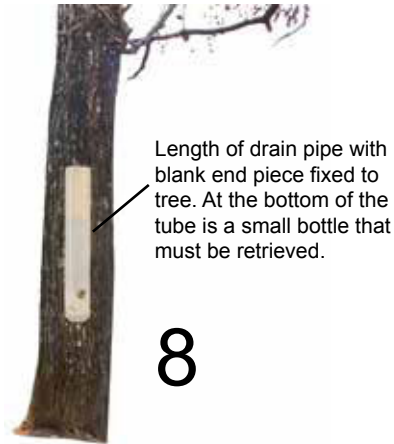

8

Challenge nine

The team are presented with a bucket of goo in the goo is a stick on which is written 'Clue below'. Teams will soon discover that by searching the goo there is no clue present and have to re-thing the clue. The clue is hidden under the base of the bucket. Goo can be porridge, wallpaper paste or custard.

Clue reveals final location of the secret base.

9



Secret base

At this location there are a number of cardboard tubes set within a play area.

The teams are provided with a string holder device in which egg is placed. Each member of the team will hold one string and they must coordinate to place the egg onto of a cardboard tube.



At the secret base other teams will arrive perhaps at the same time and each will be trying to get their egg in place. So quick timing and time advantage is a consideration. For those teams who have incurred a time penalty they must wait out a set period of time - a two minutes per life lost.

First team to complete the challenge is the winner

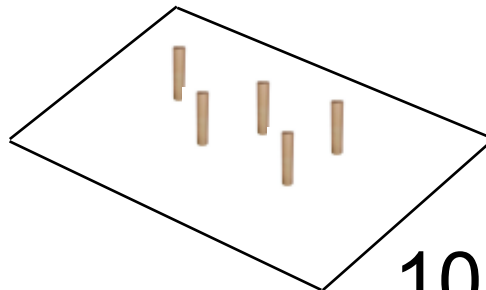

10

